

GATSBY COFFEE TABLE

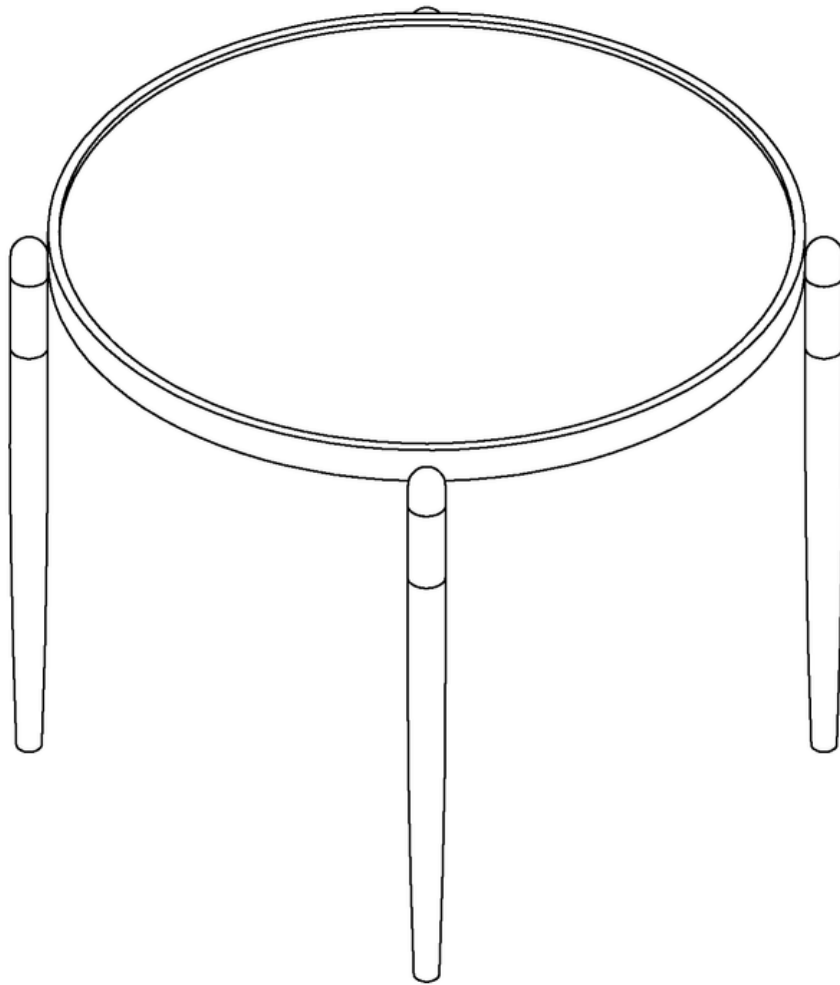

ASSEMBLY GUIDE

CONTENTS

PART LIST

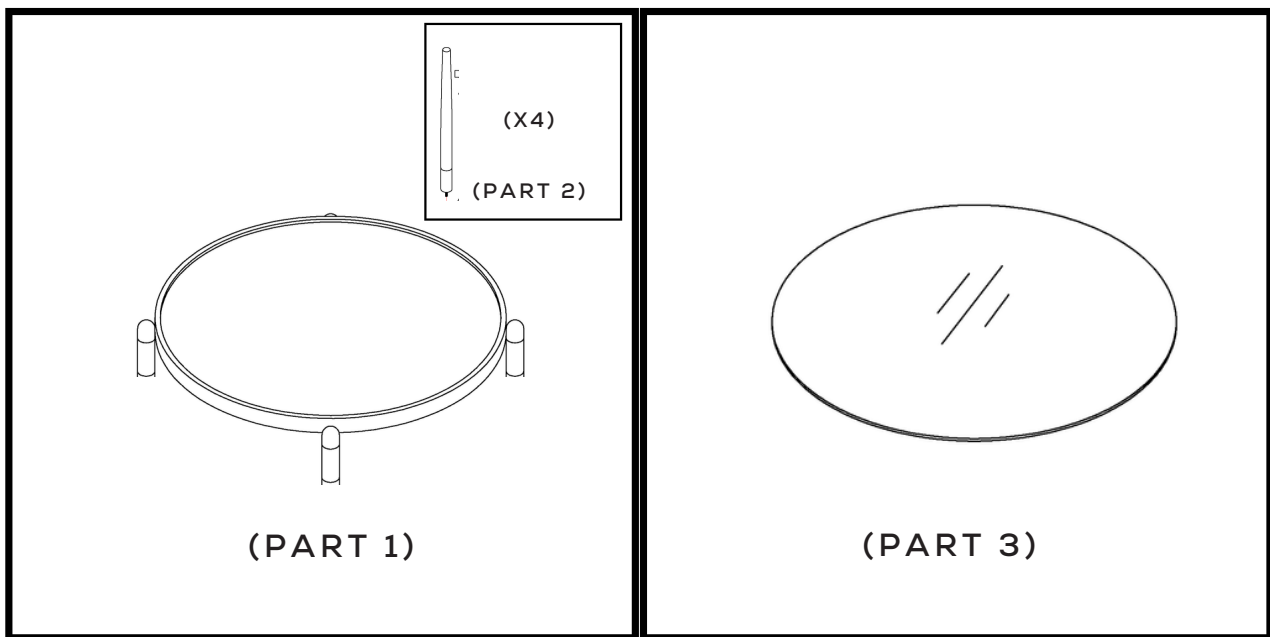

WE WANT TO BE KINDER TO THE ENVIRONMENT. THAT IS WHY WE HAVE CHOSEN TO USE LITTLE TO NO PLASTIC.

PLEASE REUSE OR RECYCLE ALL CARDBOARD PACKAGING.

ASSEMBLY STEPS

ENSURE YOU PLACE A RUG OR PROTECTIVE SURFACE DOWN TO COMPLETE ASSEMBLY. PROTECT THE FLOOR AND THE PRODUCT FINISHES.

STEP 1

LAY OUT ALL PARTS. LEAVE THE TOP WRAPPED AND PUT IT SAFELY ASIDE. IT WILL BE THE LAST PIECE USED.

STEP 2

PLACE THE FRAME (PART 1) SECURELY ON THE FLOOR

STEP 3

SCREW THE X4 LEGS (PART 2) INTO THE FRAME (PART 1)

STEP 4

ONCE ALL LEGS ARE ATTACHED AND TIGHTENED, STAND THE FRAME UPRIGHT.

STEP 5

UNWRAP THE TOP (PART 3) AND PLACE IT CAREFULLY ONTO THE FRAME

STEP 6

PLACE THE TABLE INTO POSITION AND STYLE IT WITH YOUR FAVOURITE TREASURES OR DÉCOR PIECES.

ASSEMBLY STEPS

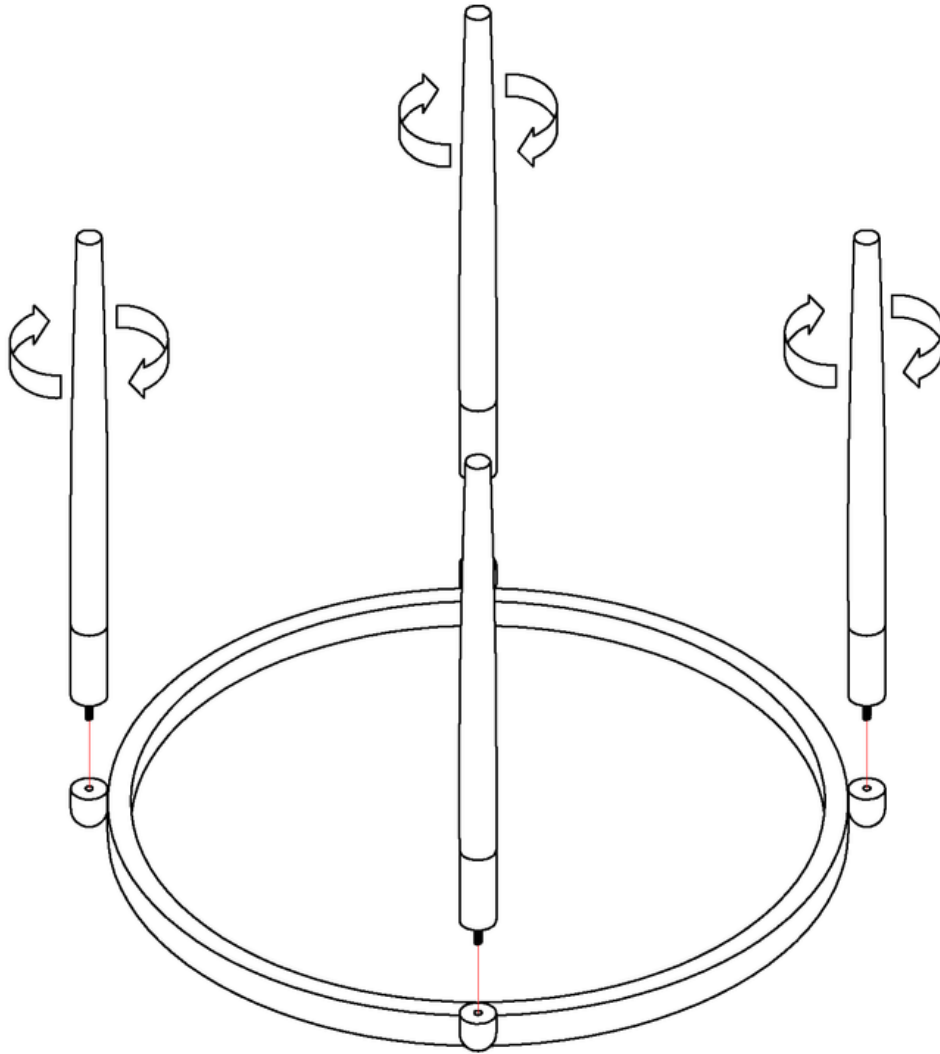

PLACE THE FRAME (PART 1) SECURELY ON THE FLOOR.
SCREW THE X4 LEGS (PART 2) INTO THE FRAME (PART 1)

NOTE: CAREFULLY ALIGN THE THREADS TO THE FRAME BEFORE TIGHTENING

ASSEMBLY STEPS

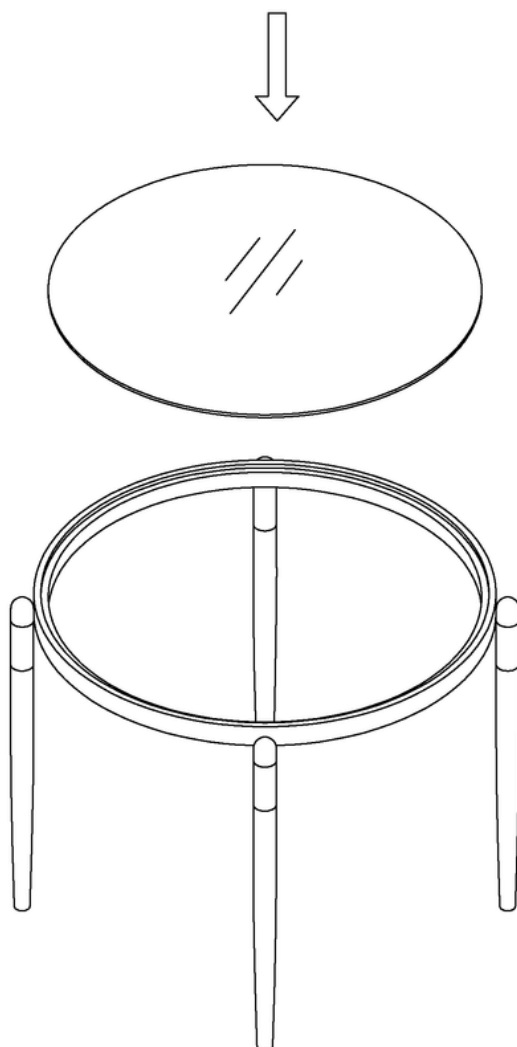

ONCE ALL LEGS ARE ATTACHED AND TIGHTENED, STAND
THE FRAME UPRIGHT.

UNWRAP THE TOP (PART 3) AND PLACE IT CAREFULLY ONTO
THE FRAME

CARE TIPS

NOTE – USE NON-ABRASIVE FURNITURE CLEANERS TO ENSURE YOUR TABLE RECEIVES THE BEST CARE.

- ALWAYS READ THE LABEL OF CLEANING PRODUCTS TO ENSURE SUITABILITY BEFORE USING.
- MILD CLEANING PRODUCTS CAN BE SAFELY APPLIED TO THE METAL'S SURFACE. JUST BE SURE TO WIPE THE SOLUTION WITH A CLEAN, SOFT CLOTH.
- GLASS CAN BE CLEANED WITH A SOFT CLOTH AND GLASS CLEANER, OR WITH A MICRO-FIBRE GLASS CLEANING CLOTH.
- USE COASTERS OR PLACEMATS TO PREVENT SCRATCHES ON THE GLASS.
- TAKE CARE WHEN HANDLING GLASS. DO NOT SIT, STAND OR LEAN ON THE GLASS. DO NOT PLACE THE GLASS DIRECTLY ONTO HARD SURFACES.

TIP – CHECK THE LEGS REGULARLY AND RETIGHTEN IF NECESSARY.