

MOSMAN BOOKSHELF

24595605

Thank you for purchasing the MOSMAN Bookshelf. Before you begin to assemble your new piece of furniture, please check to ensure that all hardware and parts have been supplied. This page lists all contents included in the carton(s).

Follow instructions closely as deviation from them may present a possible safety risk and may void your warranty.

It is recommended that assembly is done on a soft surface such as carpet to avoid any damage.

If you experience any problems with your new purchase, please contact Freedom Customer Service via www.freedom.com.au (Australia) or www.freedomfurniture.co.nz (New Zealand).

Care Information

DO

- Use tablecloths, table runners and coasters to help protect surfaces from scratching.
- Dust once a week using a soft cloth or similar duster.
- Only use freedom recommended care products as many supermarket polishes and waxes contain high levels of silicon and petroleum distillate which can damage the surface.
- Polish your furniture every 3 to 6 months, making sure the surface is free from dust before you start.





DON'T

- Do not place hot or wet items directly on the surface as they can leave marks which are difficult to remove.
- Avoid direct sunlight, as this will cause colour change. If the furniture is in direct sunlight, move items like vases around to avoid spotting.
- Do not apply too much polish as this will build up and need to be removed with a wood-cleaning product

GENERAL

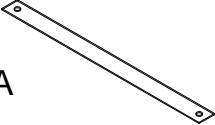
Periodically check and re-tighten all fasteners. When moving furniture always lift it rather than drag it.

Hardware (supplied)

<u>Code</u>	<u>Description</u>	<u>Qty</u>	<u>Code</u>	<u>Description</u>	<u>Qty</u>	<u>Code</u>	<u>Description</u>	<u>Qty</u>	<u>Code</u>	<u>Description</u>	<u>Qty</u>
A		2	B		2	C		2	D		2
	Anti-tilt straps			Wall plug			Self tapping screw			Leveling wedge	

Tools Required (Not Supplied)

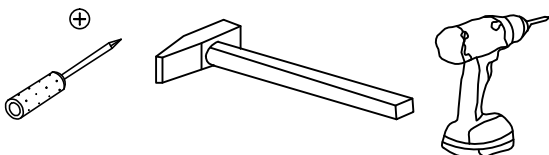

MOSMAN BOOKSHELF

24595605

NEXT STEP: Attach anti tilt strap or bracket to wall.

WARNING:

To prevent your furniture from tilting forward and possibly causing property damage or personal injury it is recommended that you **Securely attach the anti-tilt straps or brackets provided to your wall using appropriate fixings**

IMPORTANT:

- . **DO NOT** place toys or other child appealing items on top of this furniture
- . **DO NOT** open all drawers at the same time
- . **DO NOT ALLOW** small children to climb onto drawers,shelves or to swing from open doors

CAUTION:

For your safety when attaching the anti-tilt fixings;

- . Check for any electrical wires or plumbing inside the wall before drilling any holes (if you are unsure please seek professional advice is recommend)
- . Walls are constructed from different materials eg; Masonry (solid brick) or plaster board lined cavity walls (hollow).

It is important that you use the appropriate wall fixings for your wall type.

(Your local hardware store will have the necessary drills and fixings and can offer advice if needed,seeking professional advice is recommend)

MOSMAN BOOKSHELF

24595605

Step 1,

WARNING

THIS ITEM NEEDS TO BE FIXED TO A WALL

Please read these assembly instructions carefully as failure to adhere and non use of the brackets may cause the product to move and possibly lead to damage and/or injury if improperly fitted. If in doubt consult a qualified technician.

- 1, Place the unit into required position.
- 2, Ensure unit is level before securing to the wall.
- 3, Place the wall fixing bracket into position.
- 4, Mark the location point for the wall bracket fixing screw on the unit top.
- 5, Insert strap (A) into the plastic holder (B) to secure the wall bracket onto the unit top.
- 6, Please note that wall fixings such as wall plugs are not supplied—please secure the unit to the wall using the appropriate fixings for your wall type. These will be readily available from your DIY/Home improvement store.

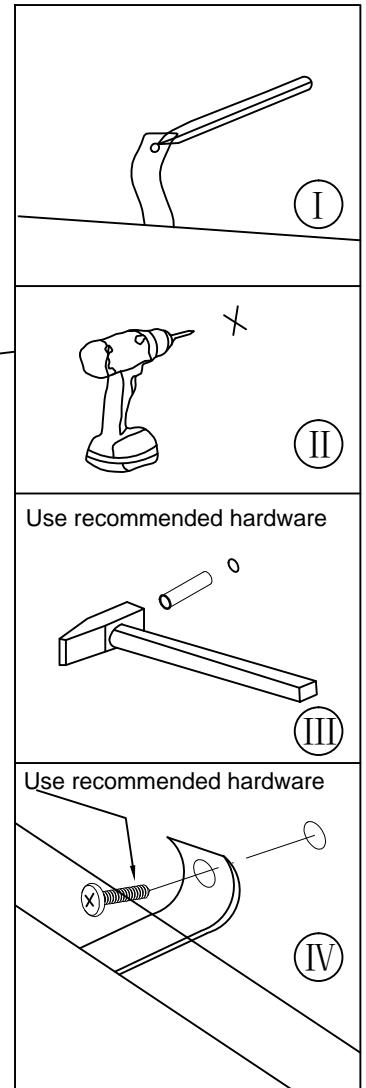
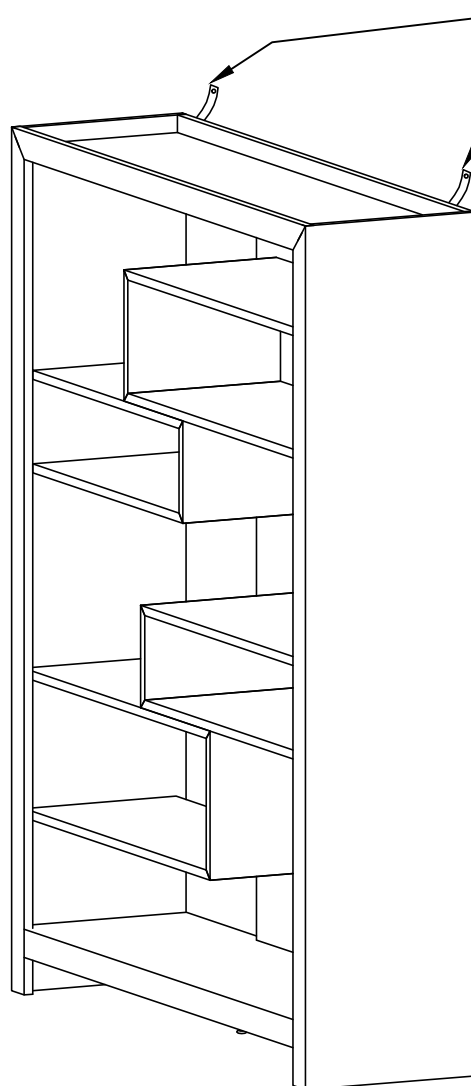

IMPORTANT!

! Once completed, ensure that all screws are firmly tightened. This one is very important for the safety of your product

MOSMAN BOOKSHELF

24595605

Step 2,

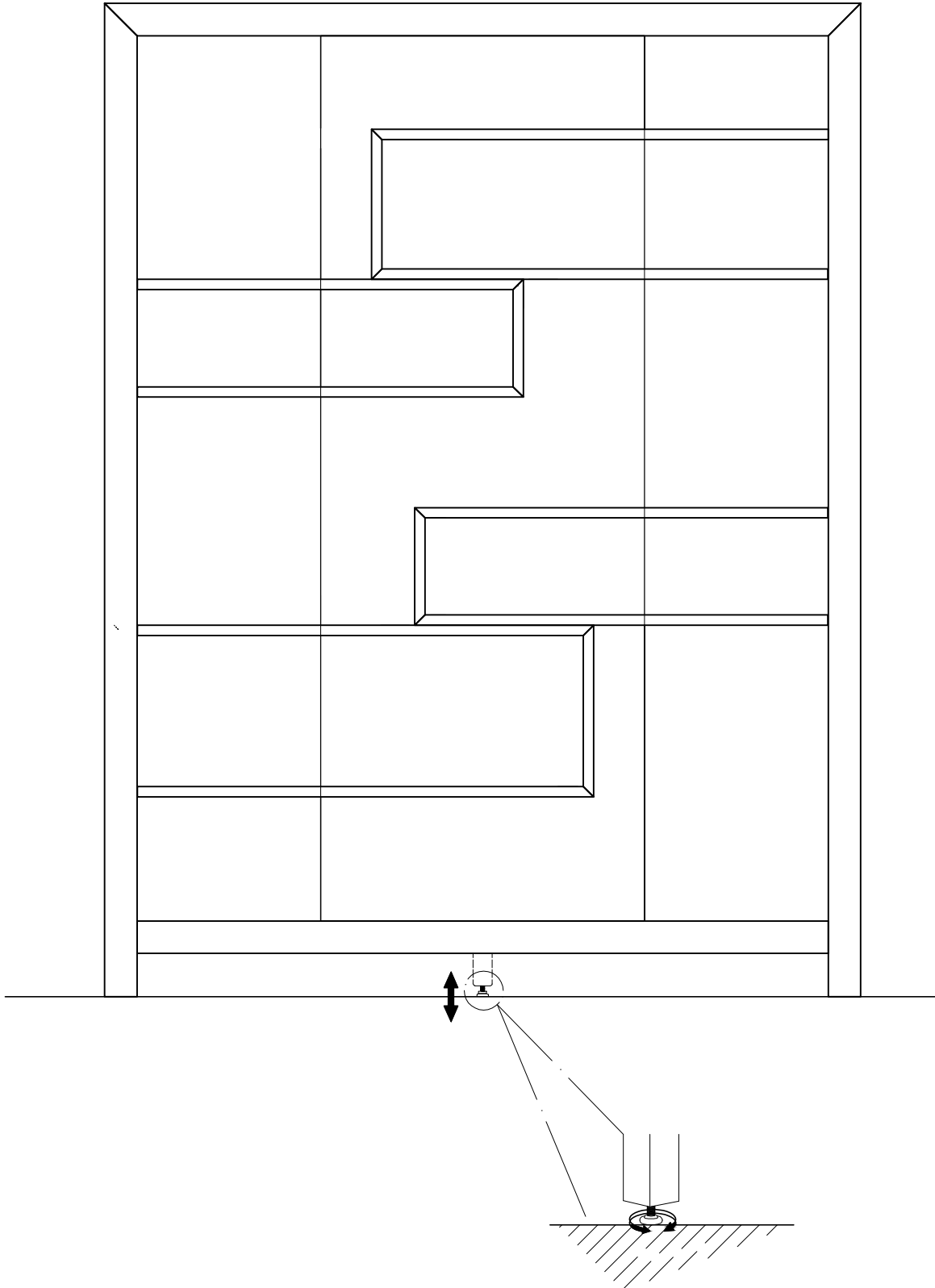

MOSMAN BOOKSHELF

24595605

Step 3,

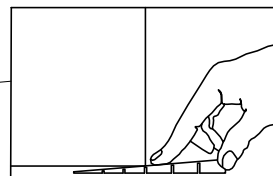
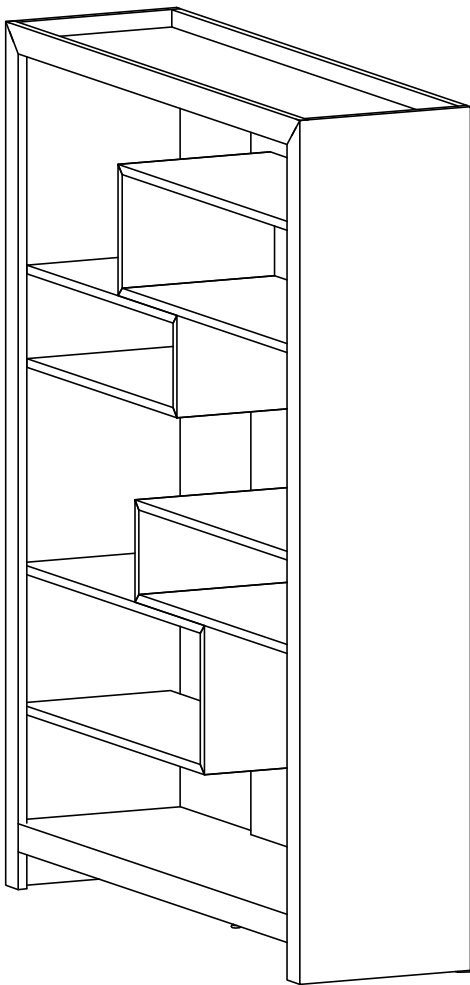

To level your cabinet, use the leveling wedge (D)

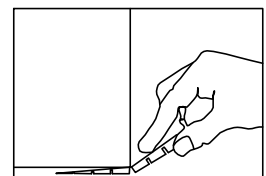

Insert the wedge (D) under the leg until cabinet is level, Break off flush to leg.