

# Day Shelving Unit Module 4

246 24 114 - 246 24 091 - 246 24 060 - 246 24 145 - 246 24 121 - 246 24 183

Thank you for purchasing the Day Shelving Unit. Before you begin to assemble your new piece of furniture, please check to ensure that all hardware and parts have been supplied. This page lists all contents included in the carton(s).

Follow instructions closely as deviation from them may present a possible safety risk and may void your warranty.

It is recommended that assembly is done on a soft surface such as carpet to avoid any damage. If you experience any problems with your new purchase, please contact Customer Service via the website [www.freedom.com.au](http://www.freedom.com.au) or [www.freedomfurniture.co.nz](http://www.freedomfurniture.co.nz)



Maximum Weight Load per shelf is 25 KG.  
Maximum Weight Load on drop down drawer is 10 KG.  
Maximum Weight Load in each drawer is 15 KG.

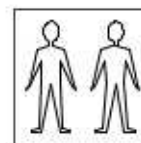

2 Person  
Assembly and  
Lifting.

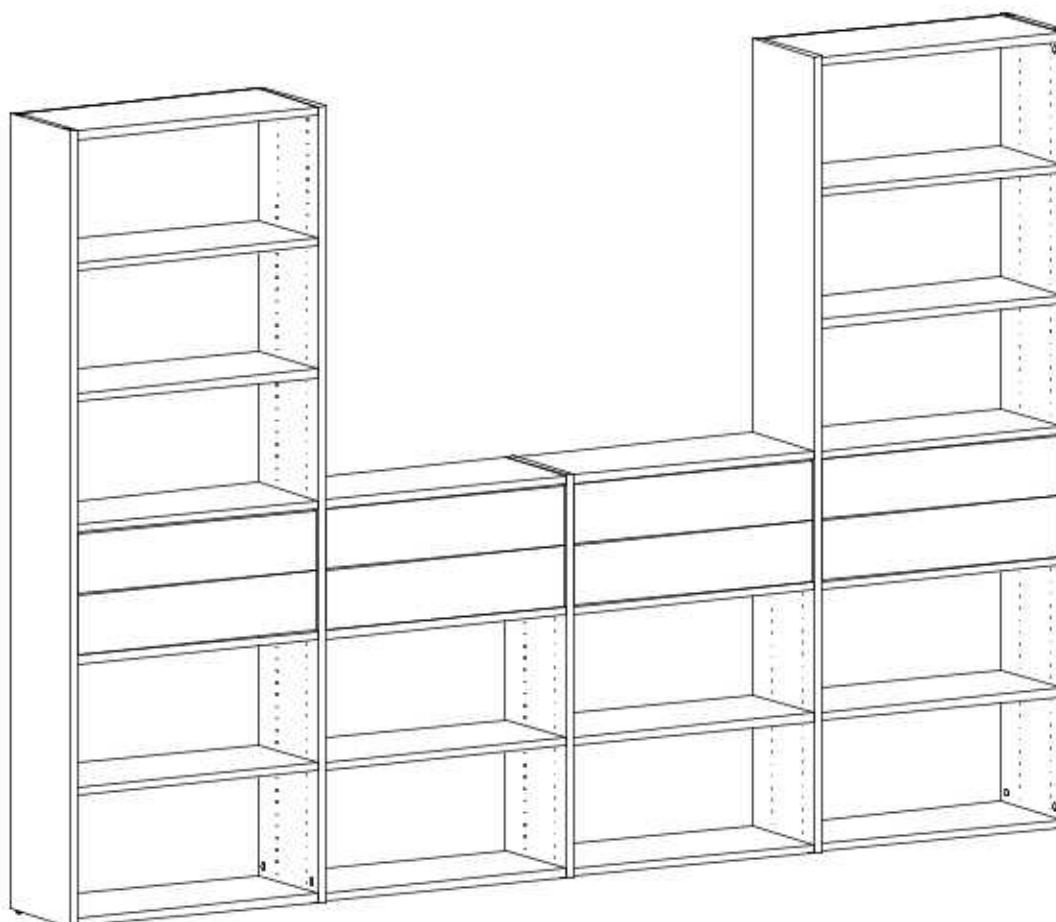

Tools Required (Not Supplied)

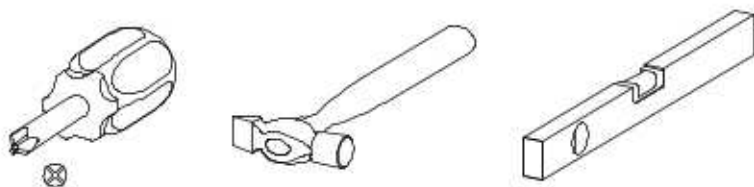

1x Carton no.: **246 24 114**

Parts and Hardware included in box:

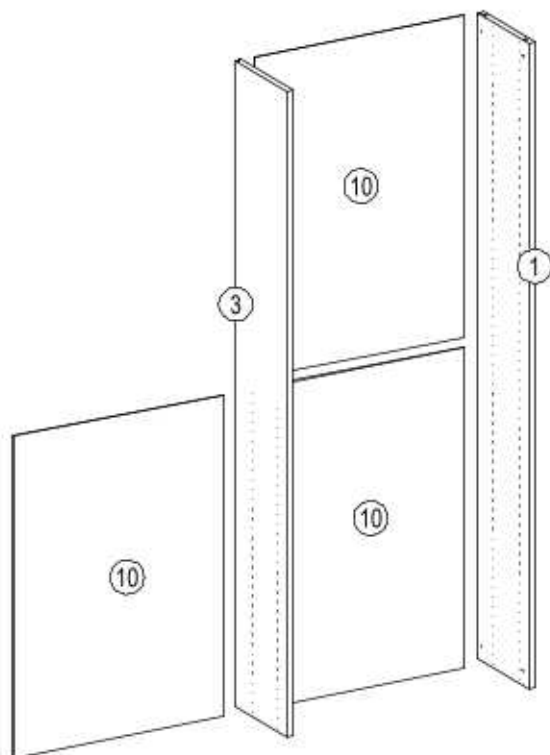
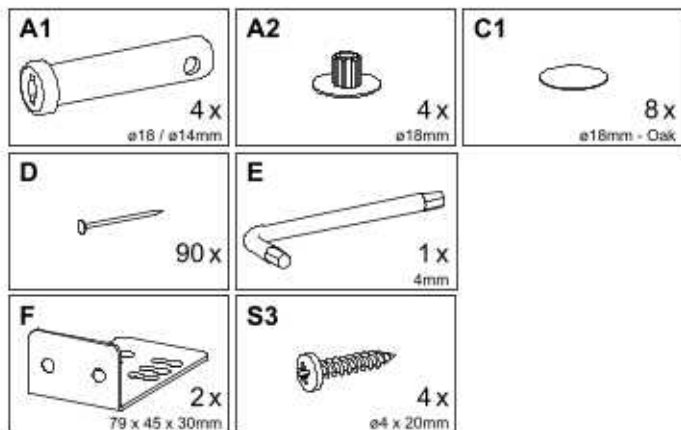

1x Carton no.: **246 24 091**

Parts and Hardware included in box:

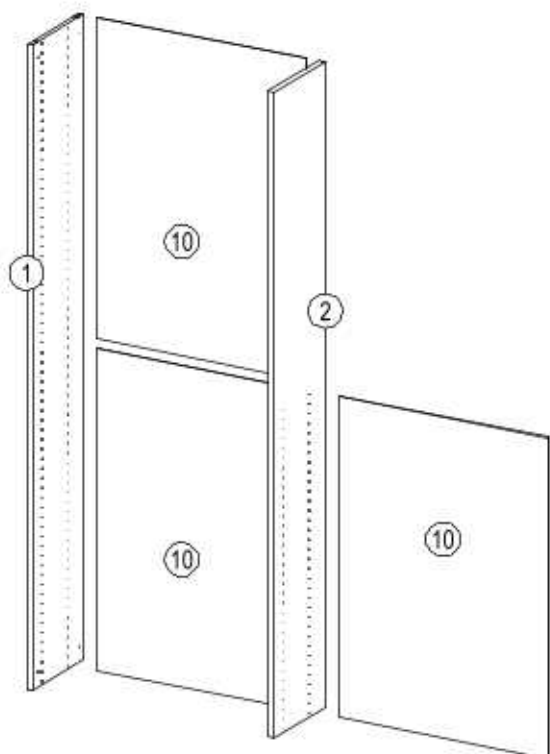
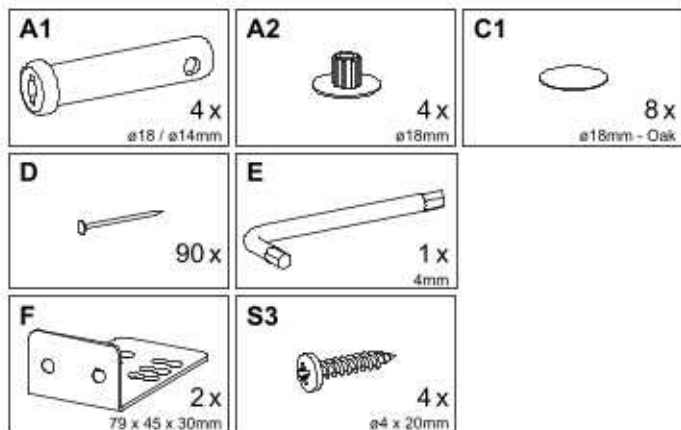

1x Carton no.: **246 24 060**

Parts and Hardware included in box.

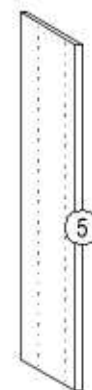
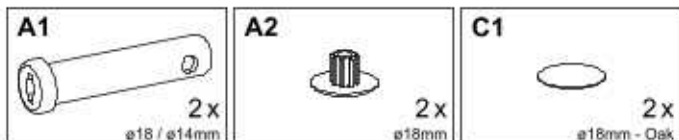

3x Carton no.: **2**

Parts and Hardware included in box.

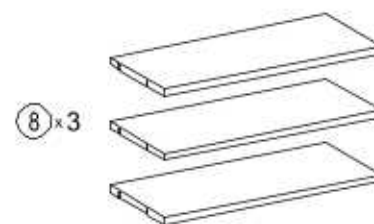
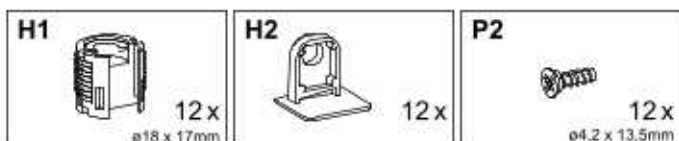

4x Carton no.: **246 24 121**

Parts and Hardware included in box.

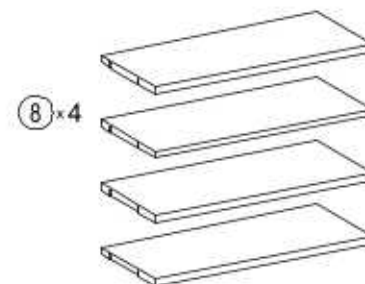
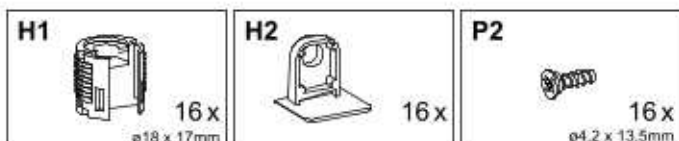

4x Carton no.: **246 24 183**

Parts and Hardware included in box.

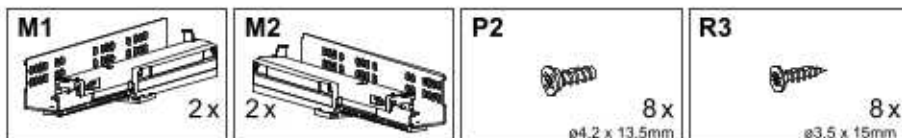

## Step 1

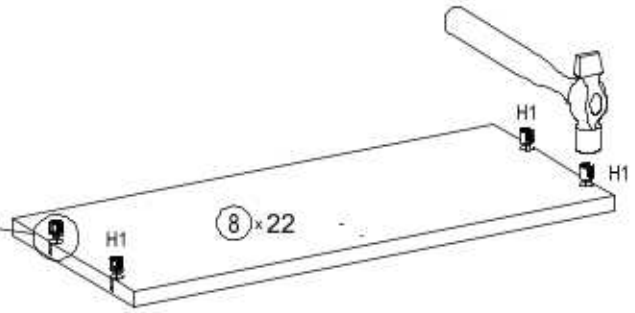
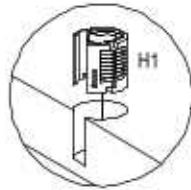
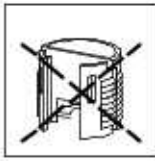
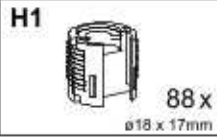

## Step 2

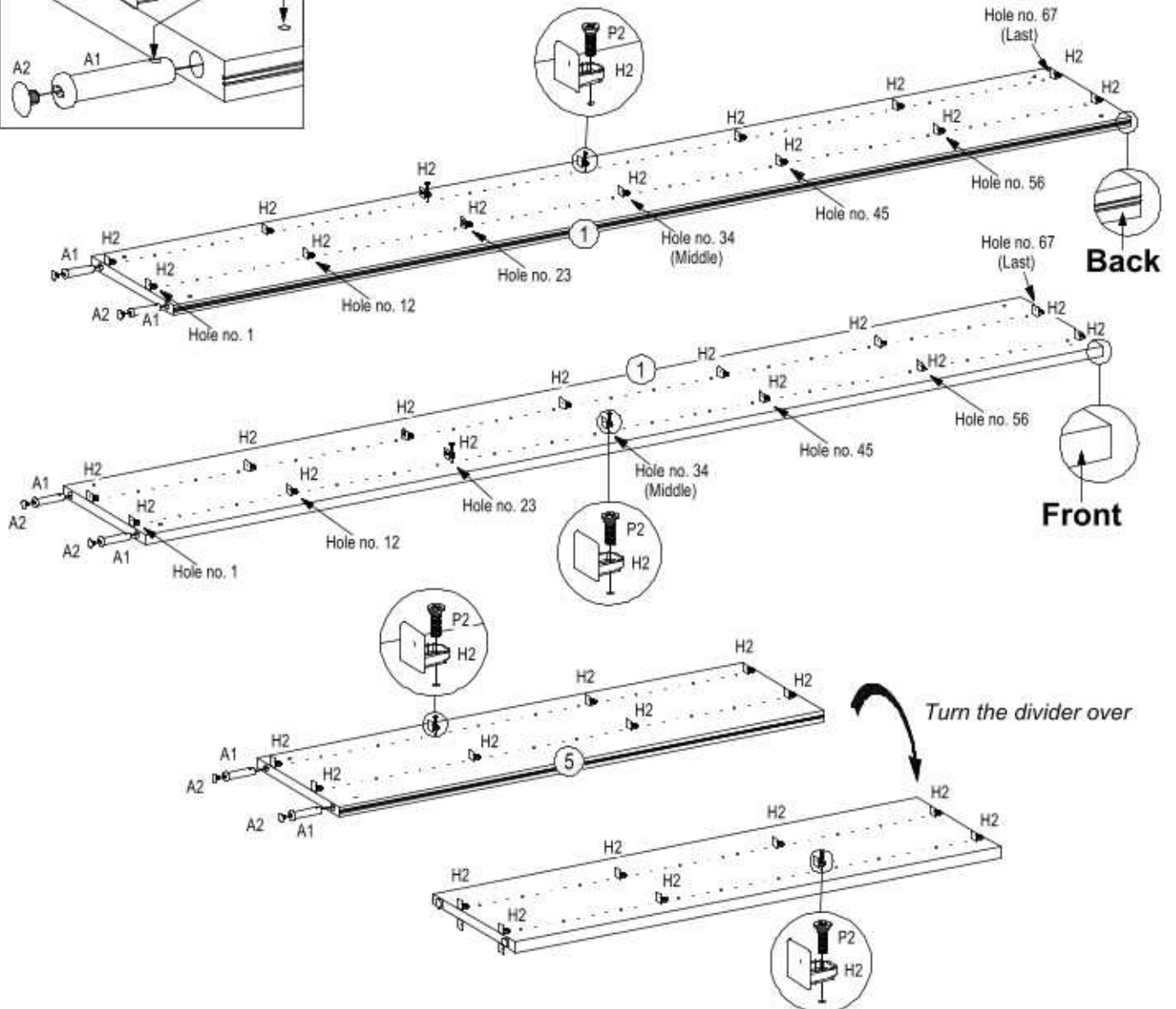
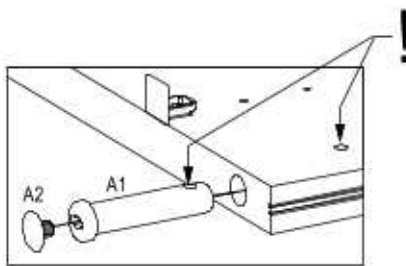
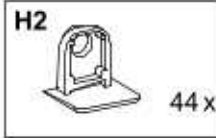
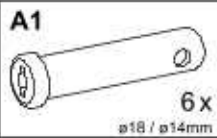

### Step 3

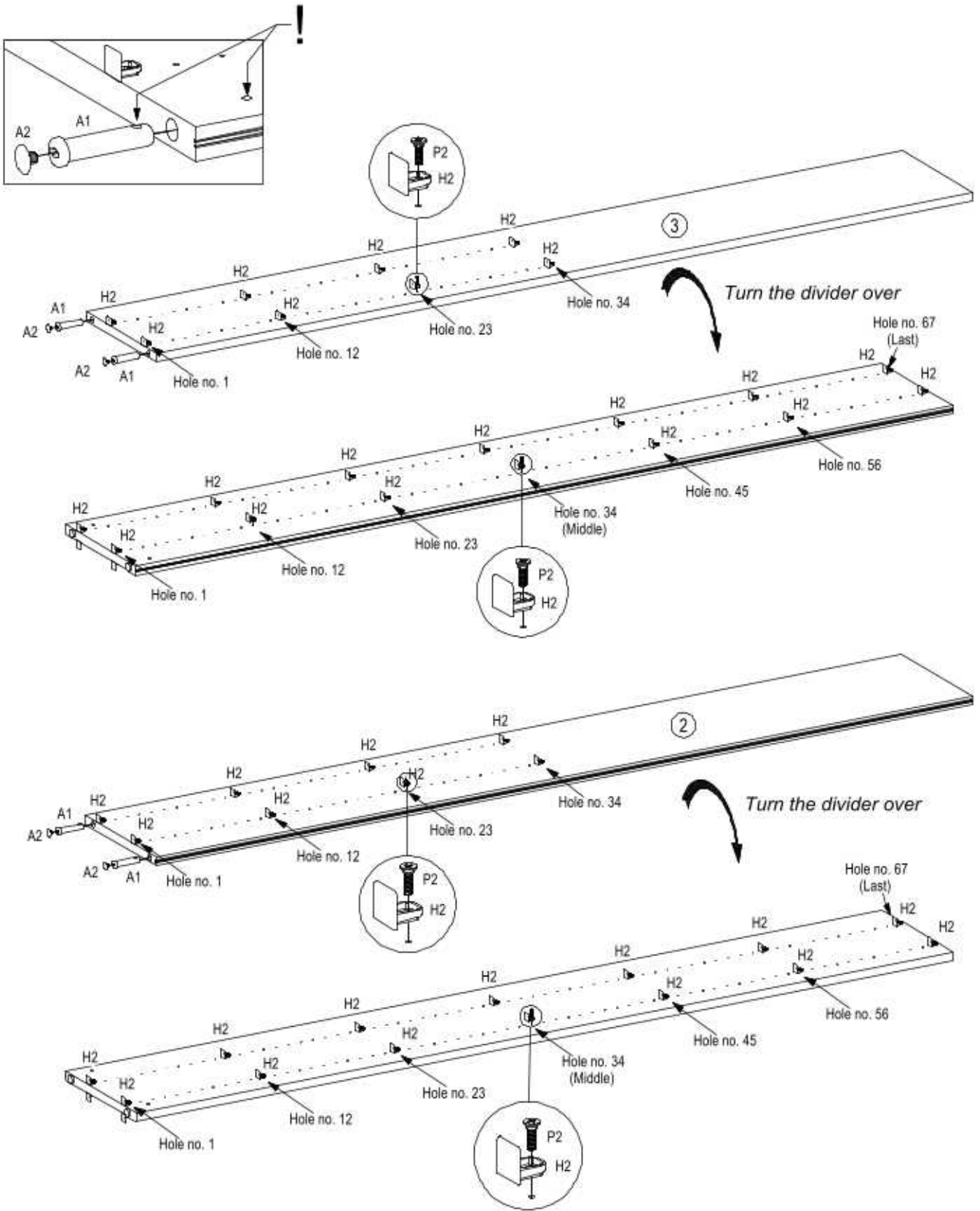
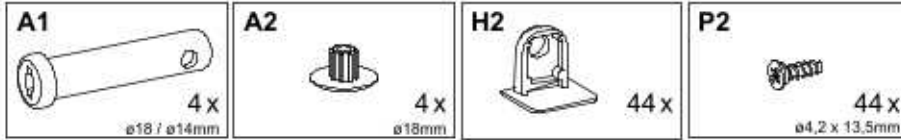

## Step 4

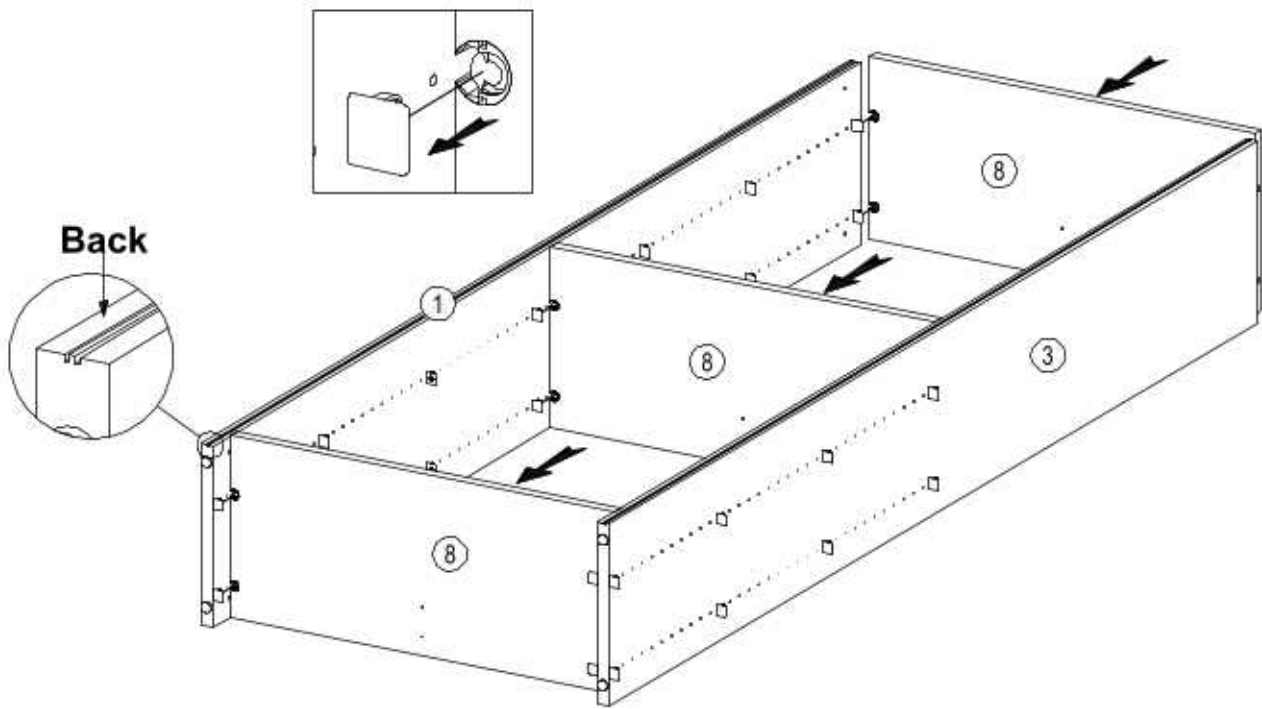

## Step 5

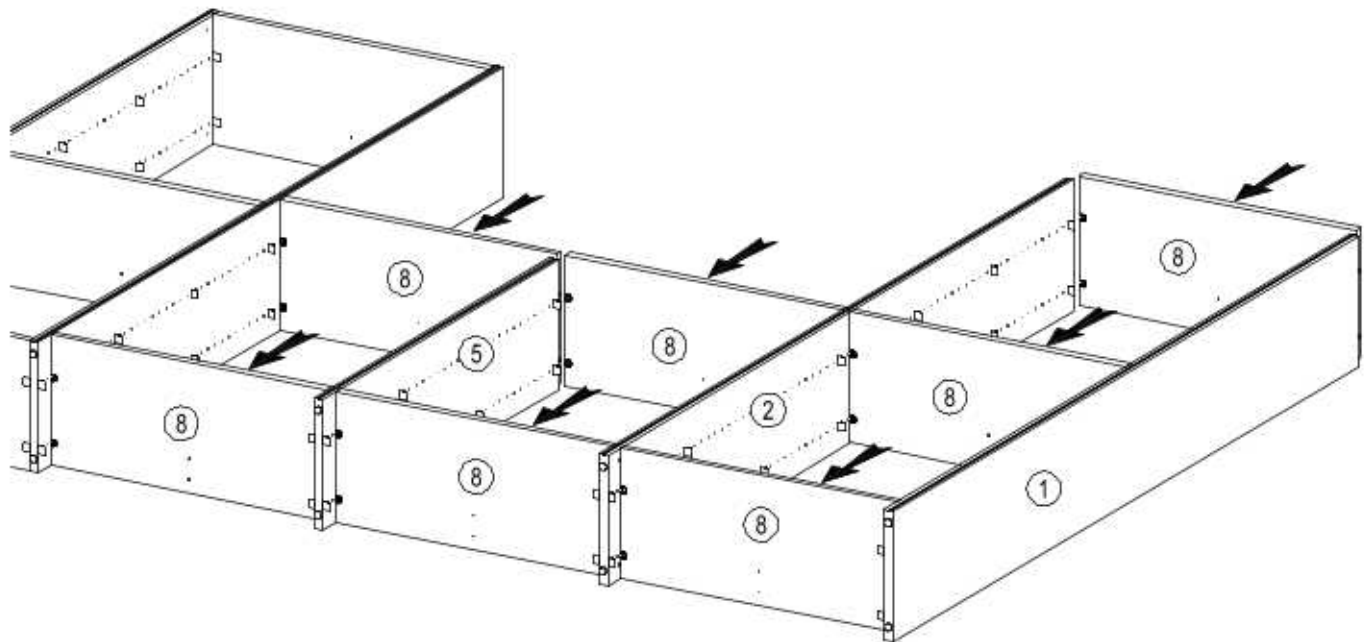

### Step 6

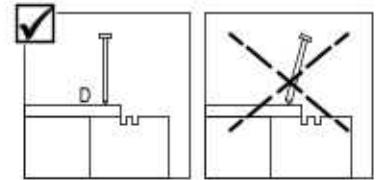

Ensure nails are put in straight not at an angle.

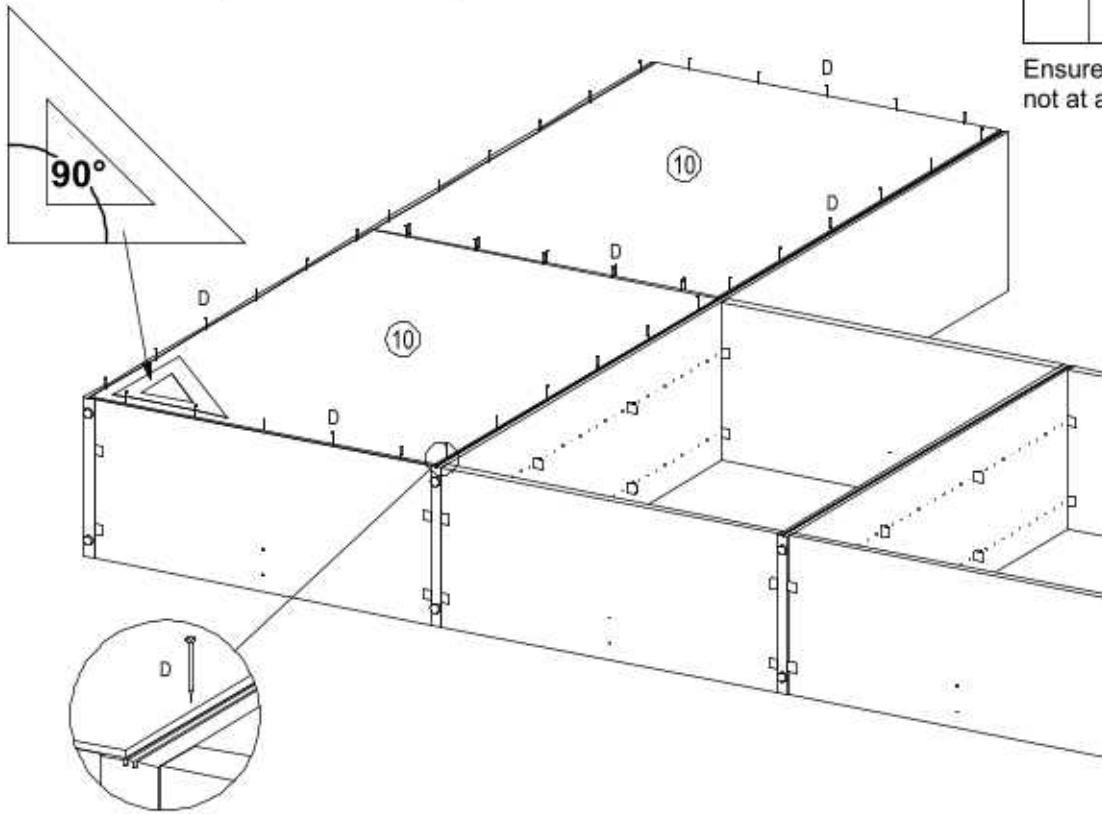

### Step 7

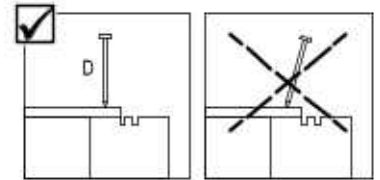
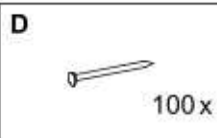

Ensure nails are put in straight not at an angle.

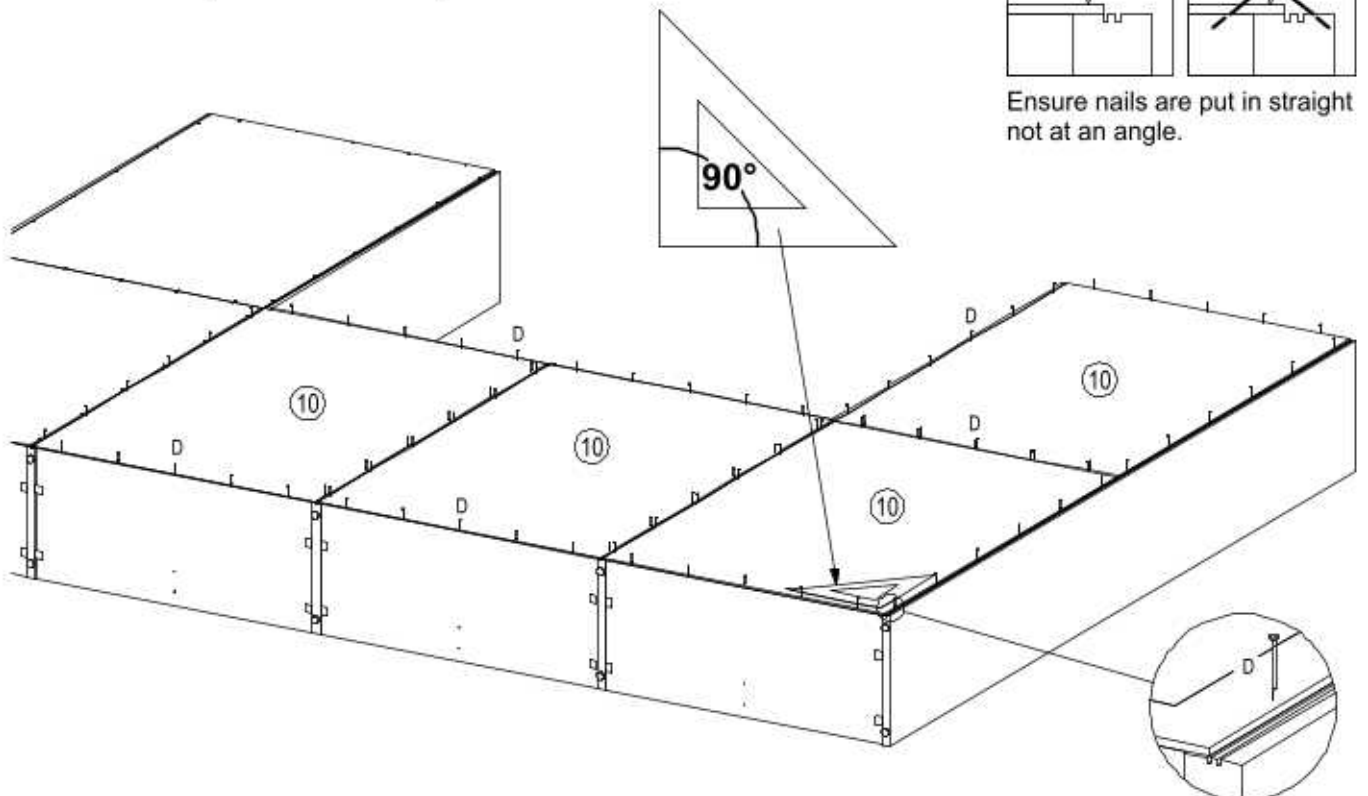

## Step 8

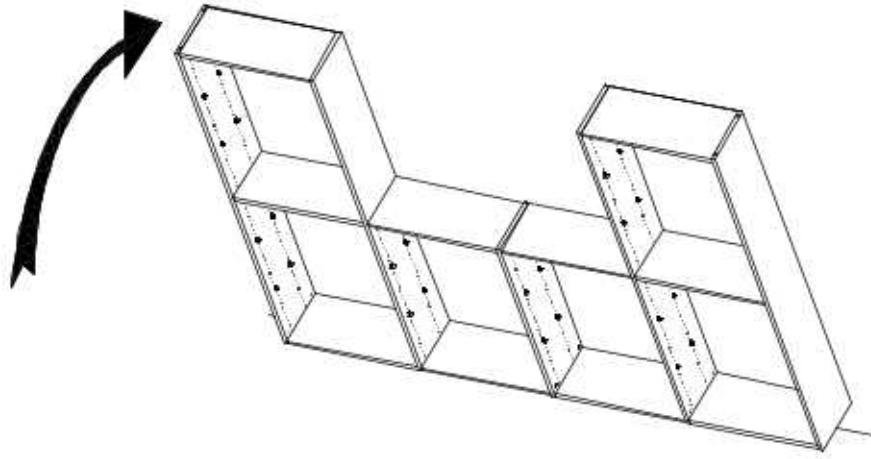

## Step 9

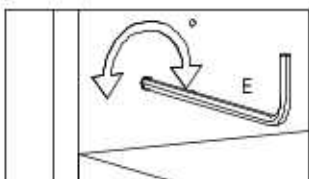
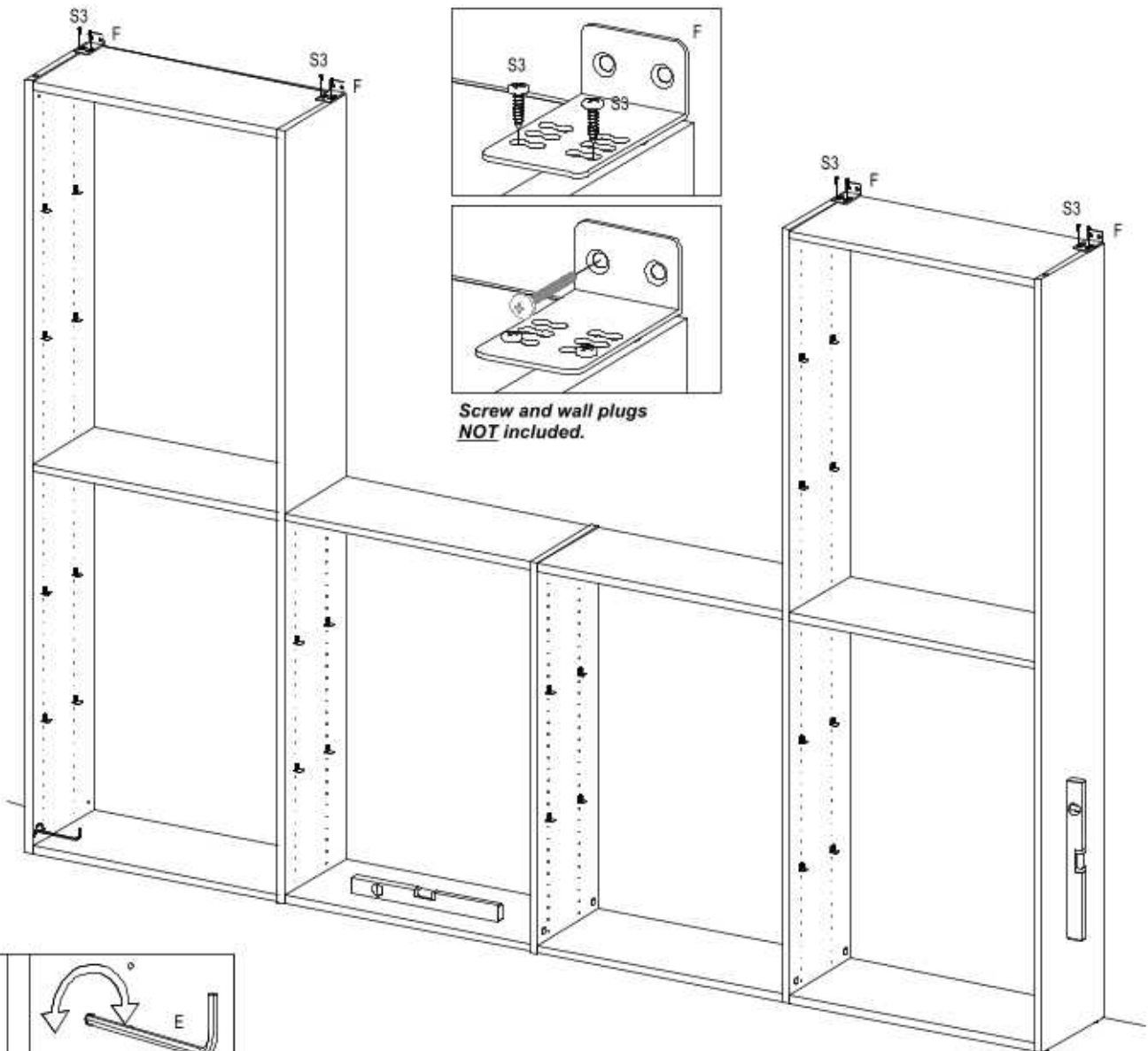
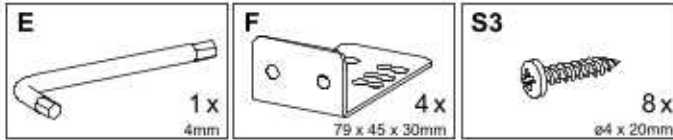



# Step 10

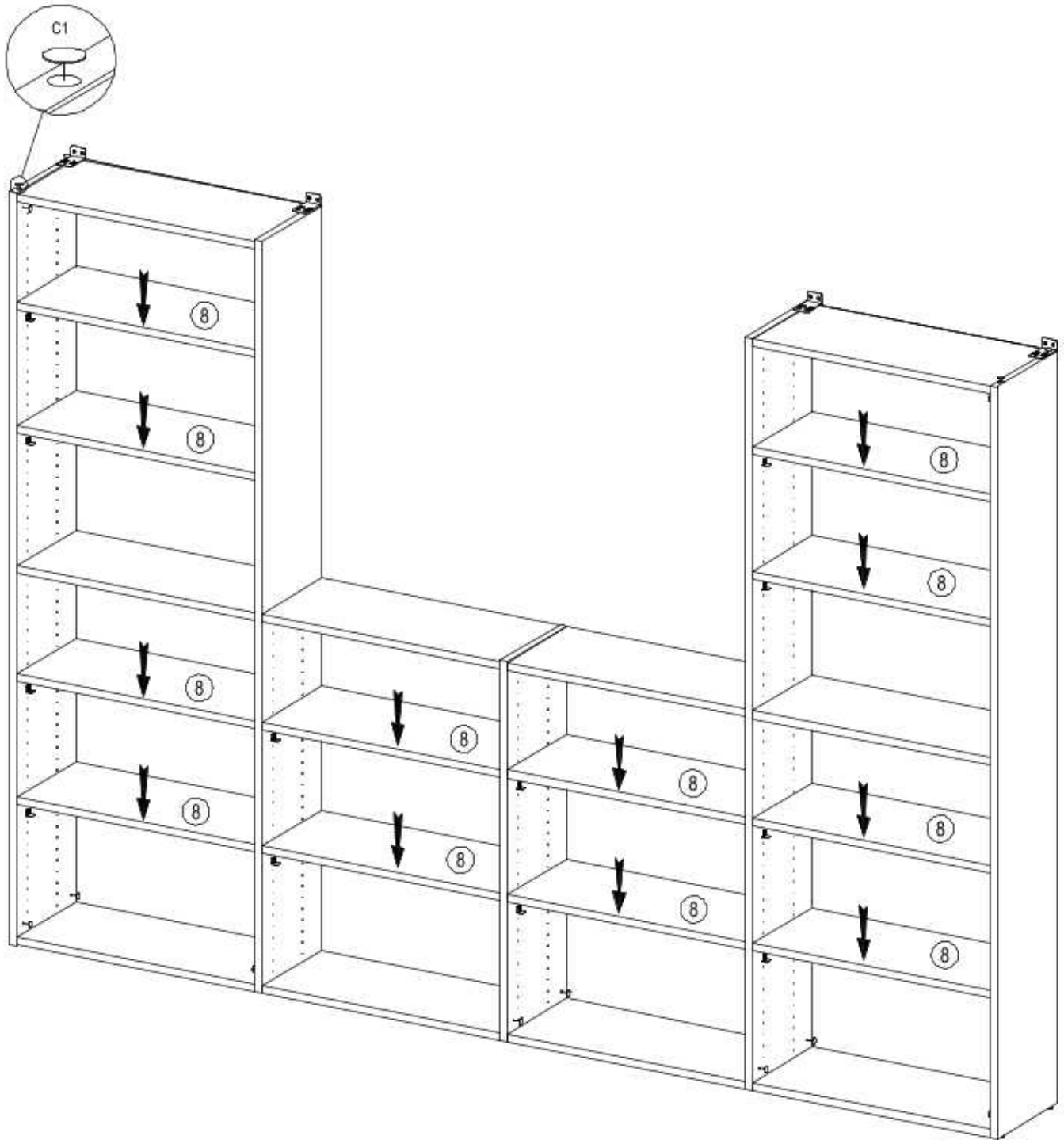
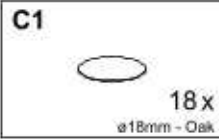

# Step 11

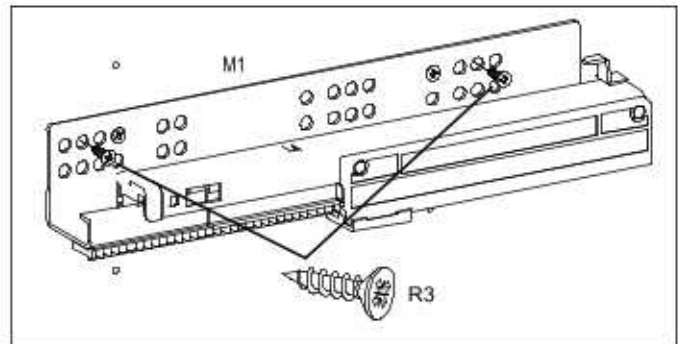
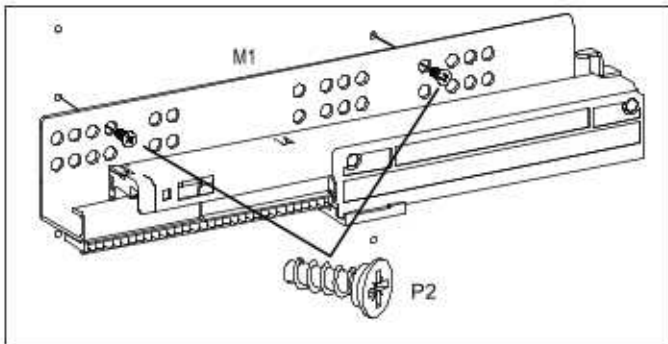
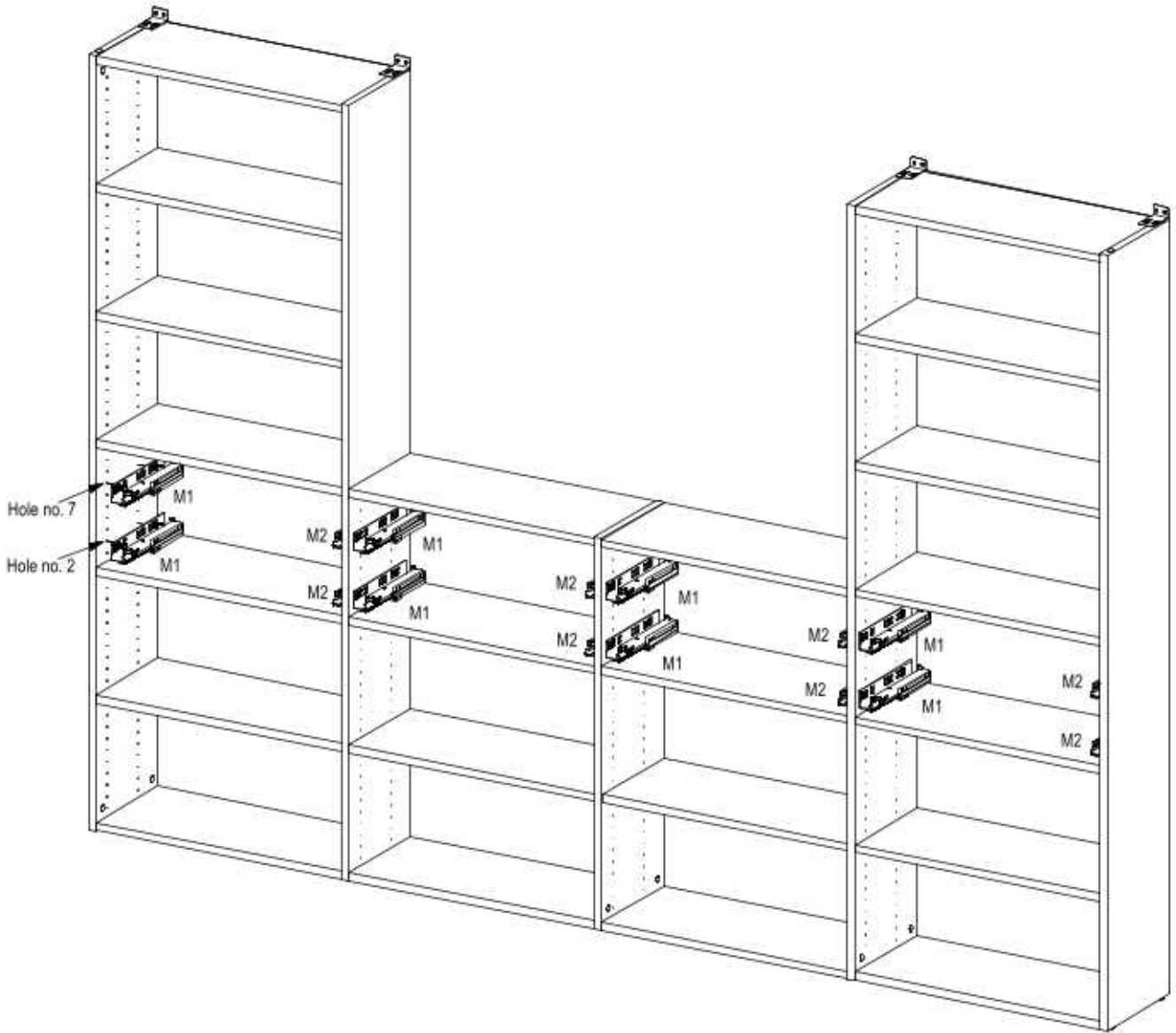
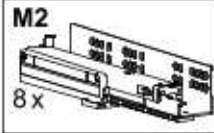
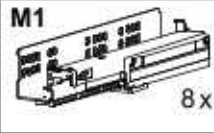

## Step 12

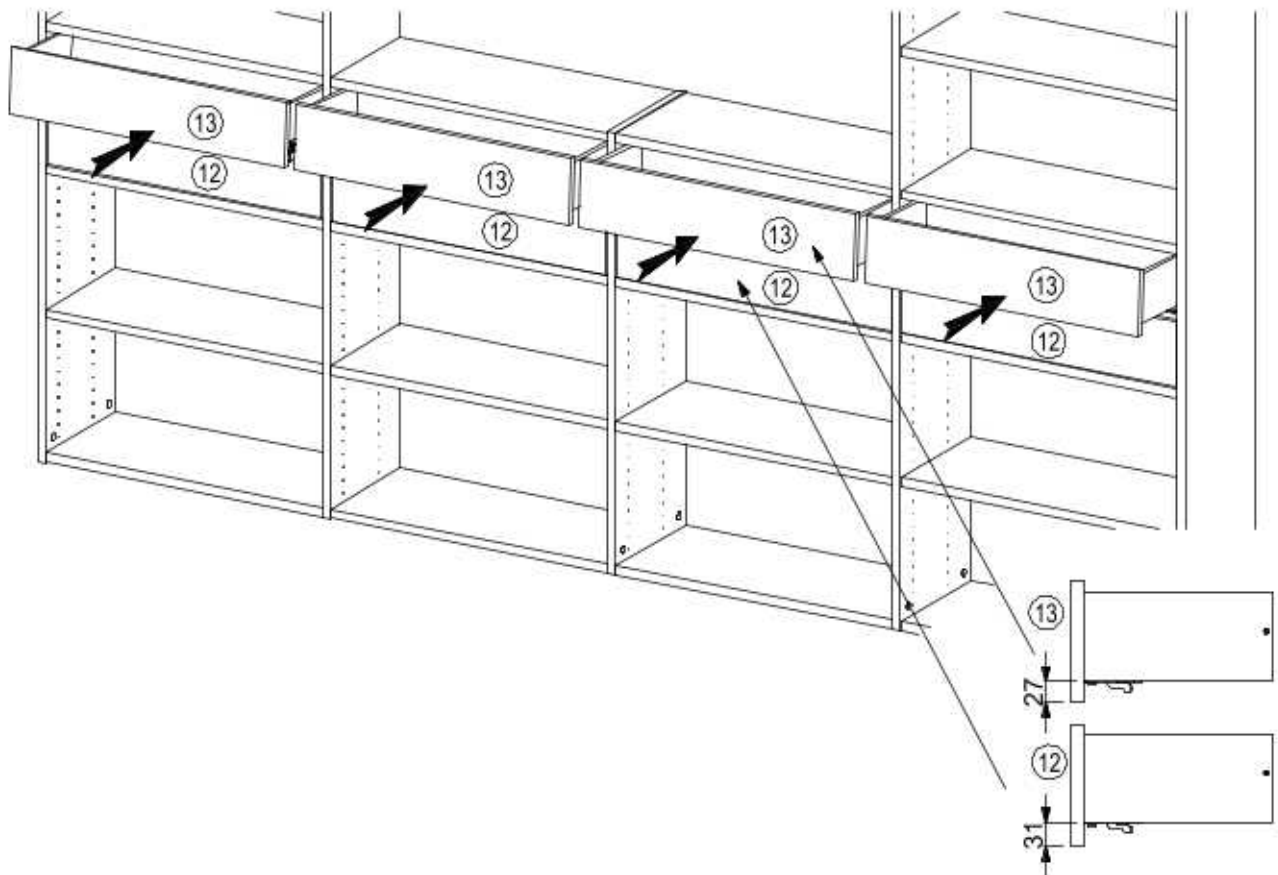

## Step 13

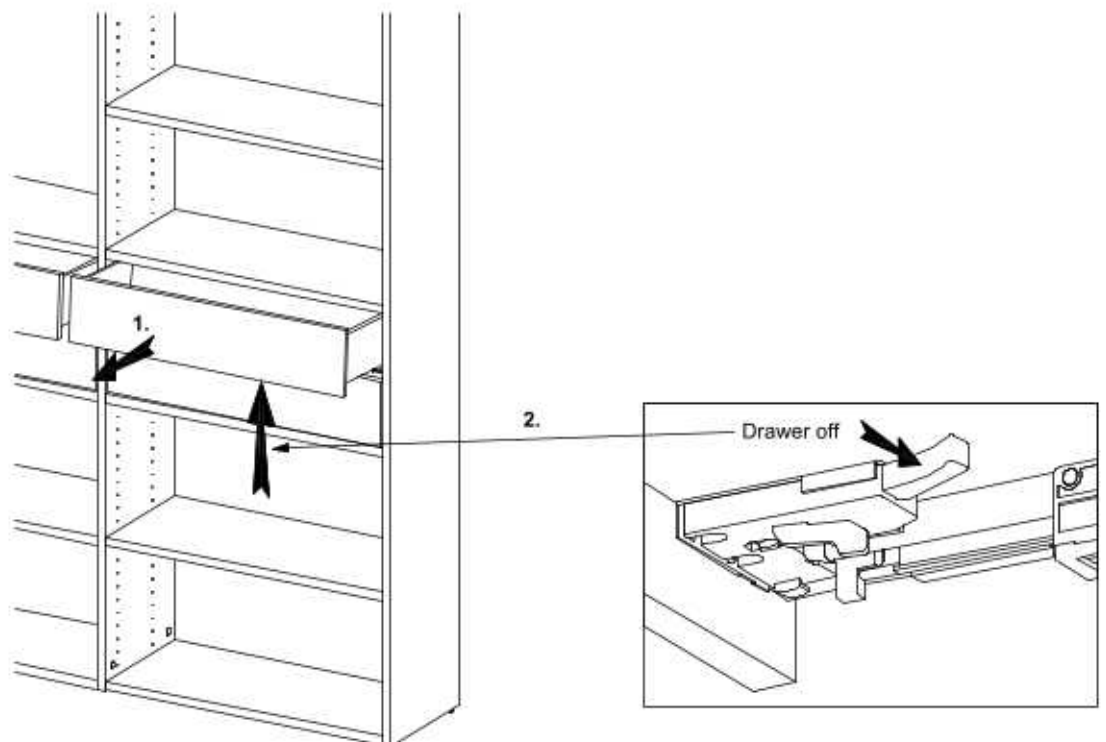

# Day Shelving Unit - Drawers

**246 24 183**

Thank you for purchasing the Day Shelving Unit. Before you begin to assemble your new piece of furniture, please check to ensure that all hardware and parts have been supplied. This page lists all contents included in the carton(s).

Follow instructions closely as deviation from them may present a possible safety risk and may void your warranty.

It is recommended that assembly is done on a soft surface such as carpet to avoid any damage. If you experience any problems with your new purchase, please contact Customer Service via the website [www.freedom.com.au](http://www.freedom.com.au) or [www.freedomfurniture.co.nz](http://www.freedomfurniture.co.nz)

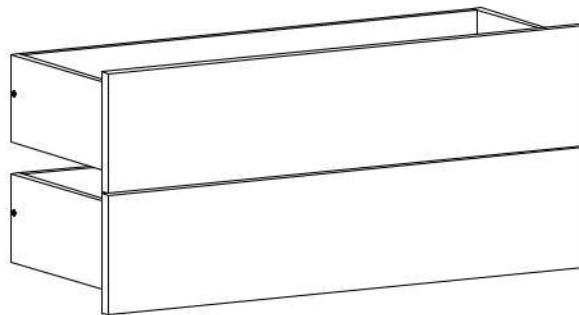









## Tools Required (Not Supplied)

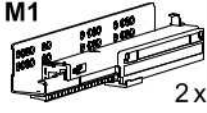
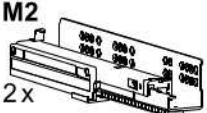
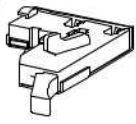
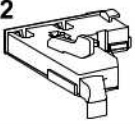

1x Carton no.: **246 24 183**

Parts and Hardware included in box.

<b>B1</b>  8 x cc34 / ø3 x 11mm	<b>B2</b>  8 x ø12 x 10mm	<b>C2</b>  8 x ø18mm - Charcoal
<b>L</b>  4 x ø5 x 38mm	<b>M1</b>  2 x	<b>M2</b>  2 x
<b>N1</b>  2 x	<b>N2</b>  2 x	
<b>P1</b>  8 x ø4.2 x 9.5mm	<b>R3</b>  8 x ø3.5 x 15mm	<b>S1</b>  6 x ø3.5 x 10mm

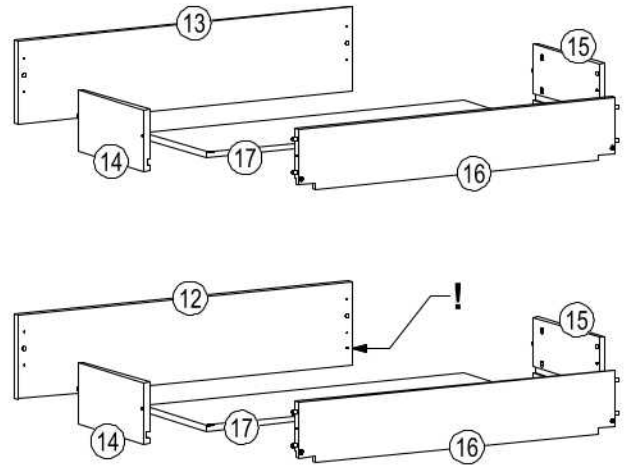

### Step 1

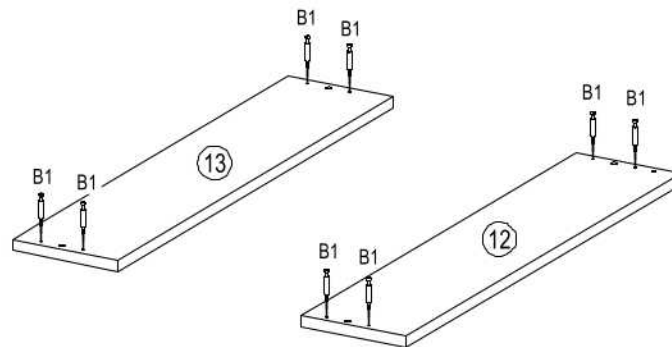
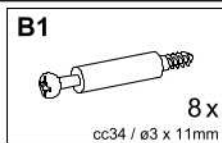

### Step 2

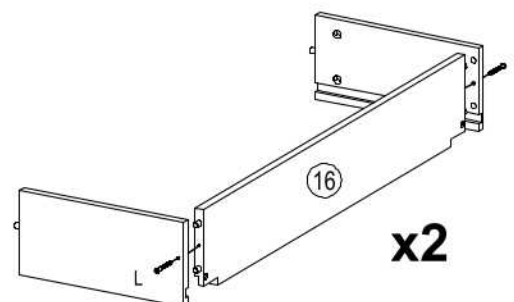
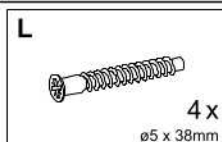

### Step 3

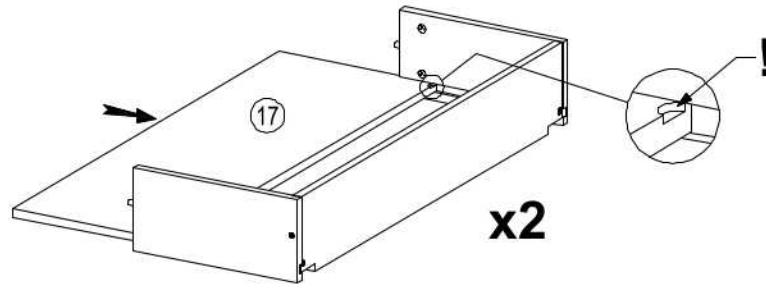

### Step 4

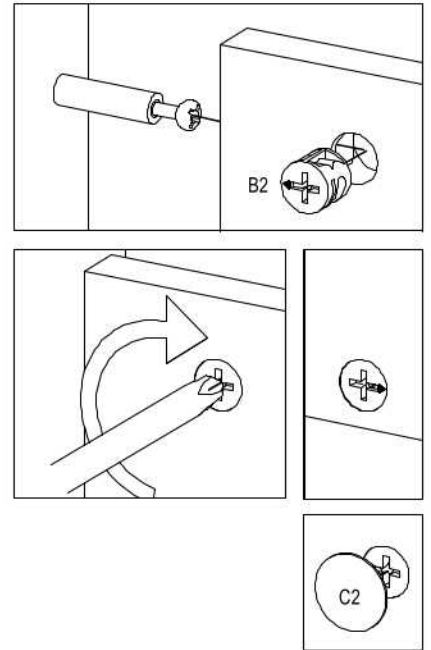
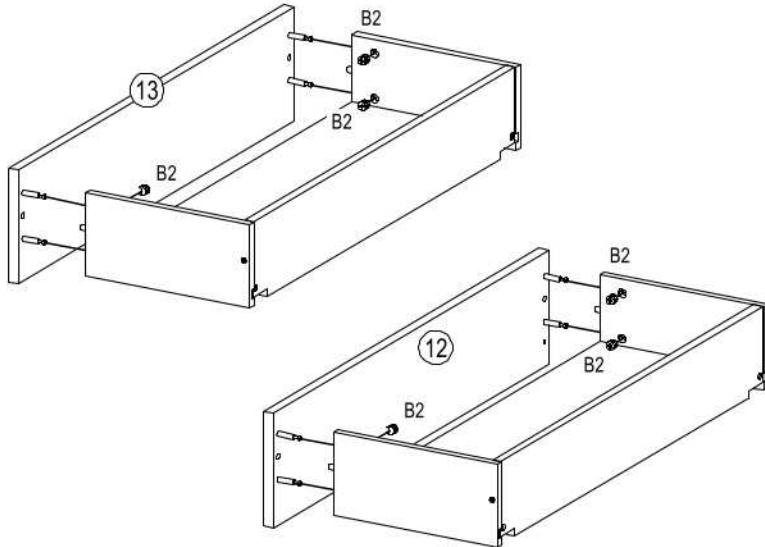
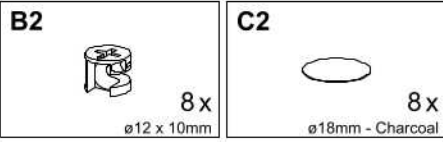

### Step 5

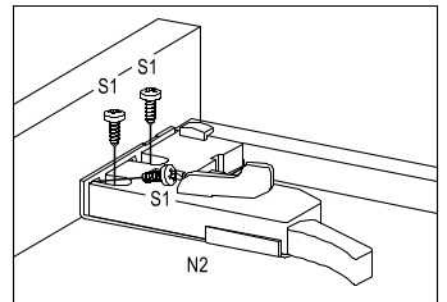
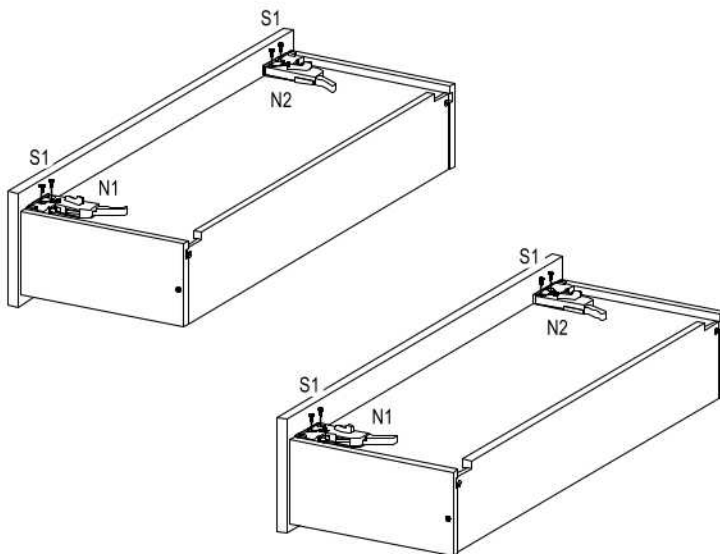
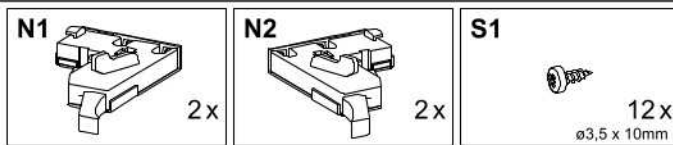

# WARNING ADDENDUM

Thank you for purchasing the Day Shelving Unit. Before you begin to assemble your new piece of furniture, please check to ensure that all hardware and parts have been supplied. This page lists all contents included in the carton(s).

Follow instructions closely as deviation from them may present a possible safety risk and may void your warranty.

It is recommended that assembly is done on a soft surface such as carpet to avoid any damage. If you experience any problems with your new purchase, please contact Customer Service via the website [www.freedom.com.au](http://www.freedom.com.au) or [www.freedomfurniture.co.nz](http://www.freedomfurniture.co.nz)

Please see amendment below for attaching the runners to the shelving units.

